

ERC080-120VH

ELECTRIC POWERED CUSHION TIRE TRUCKS

2362-1A

The Yale® ERC-VH cushion tire, electric sit-down rider lift truck is available in 8,000 – 12,000 pound capacities and is designed for demanding applications that require clean, quiet-running, heavy-duty capability. These trucks offer plenty of power and high stacking ability, while also offering excellent ergonomics, reliability and maintenance ease. There are 4 models available in two wheelbases, a short (ERC080VH & ERC100VHS) and a long (ERC100VH & ERC120VH). The ERC100VH (long wheelbase) allows the use of a larger, higher capacity battery in the 10,000 pound capacity truck.

AC TRANSISTOR TRACTION CONTROL

AC technology offers smooth acceleration and directional changes, proportional regenerative braking and the Auto Deceleration System. The controller converts battery power to three phase AC power, and adjusts frequency and current to meet performance demands. Performance control settings and extensive diagnostics are accessible by technicians through the dash display or a PC. A Vehicle Systems Manager utilizing CANbus technology monitors and controls key truck components and systems. The advanced thermal management system monitors component temperature and gradually adjusts performance to prevent damage to key components.

CONTROLLER AREA NETWORK (CANBUS)

CANbus technology streamlines communications between truck systems through one main master controller, the Vehicle System Manager (VSM). Dash display, traction controller and pump controller are all controlled via the CANbus network. A connection point is provided for interface with a service PC. Intellix VSM acts as a master truck controller, providing extensive monitoring and control of truck functions and systems. CANbus technology reduces wiring complexity and enables comprehensive communications between truck systems. The ergonomically positioned dash display transmits continual feedback to the operator and allows for communication of service codes.

ELECTRICAL SYSTEM

The ERC-VH utilizes AC motor technology designed for exceptional performance. It uses a brushless induction motor for high starting torque and smooth rapid acceleration. An external speed sensor provides feedback to the control system, allowing motor speed and direction to be continuously monitored.

POWER ASSISTED BRAKING

Power Assisted Braking is accomplished via the VSM. The VSM monitors brake-line pressure. When this pressure exceeds a set threshold the VSM sends a signal to the traction controller to decelerate the traction motor proportionally to the brake pressure. The higher the brake pedal pressure being applied, the more quickly the truck will decelerate. The wet disc brakes in conjunction with the Power Assist Braking system, reduce brake pedal effort and provides increased stopping power. These brakes offer 4,000 hr. service intervals (oil change) with no adjustments

required and simplified brake line plumbing for durability. The master cylinder is sealed and has an external fluid level sensor connected to a warning icon on the instrument module. The ERC-VH features an Automatic Park Brake that is applied by a spring when the truck is stationary. Upon sensing a demand at the accelerator pedal, the brake is released. A manual override (located underneath the floor plate) is provided to disengage the brake if the truck has to be moved during service conditions in the absence of power on the truck. The standard Auto Deceleration System automatically slows the truck when the operator's foot is removed from the accelerator pedal, extending brake life.

VOLTAGE

36, 48, and 80 volt systems are available in two battery compartment sizes to meet a variety of application requirements.

OPERATOR INTERFACE DISPLAY

The repositioned display is conveniently located in the upper right area of the operator's compartment. The display includes an hour meter, LCD display for status codes and descriptions, battery discharge indicator with lift interrupt, warning icons for brake fluid, seat belt indicator, performance mode indicator, and parking brake indicator. The display also permits access for service technicians to adjust performance control settings, allowing the truck to be customized to meet customer applications. Additionally, extensive diagnostics allow service technicians to quickly troubleshoot problems. Operator selectable performance modes are standard. Available options include: Operator Password, Pre-shift Operator Checklist, Impact Monitor, System Monitor and Maintenance Reminder.

(continued on back)



Truck shown with optional equipment.

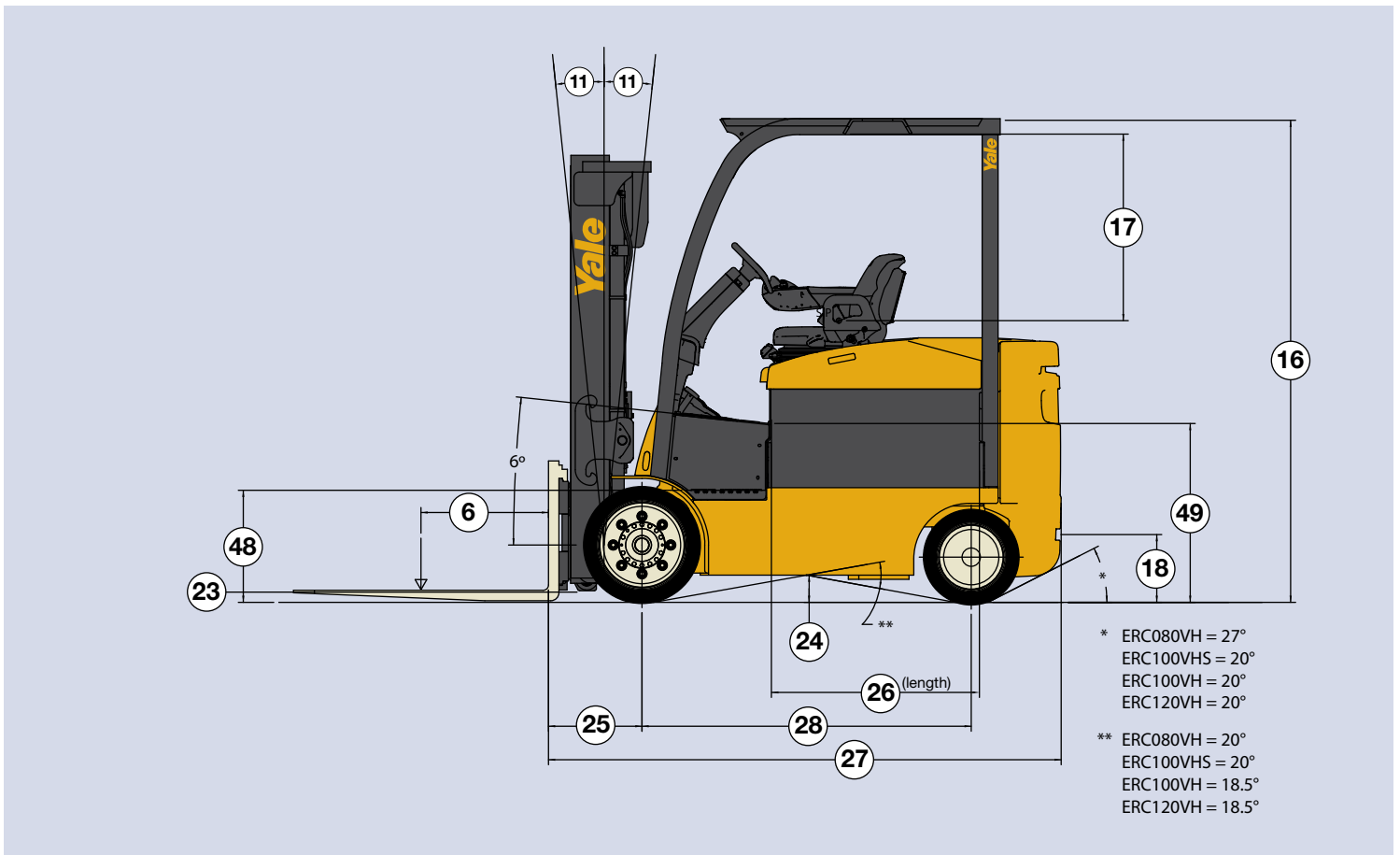
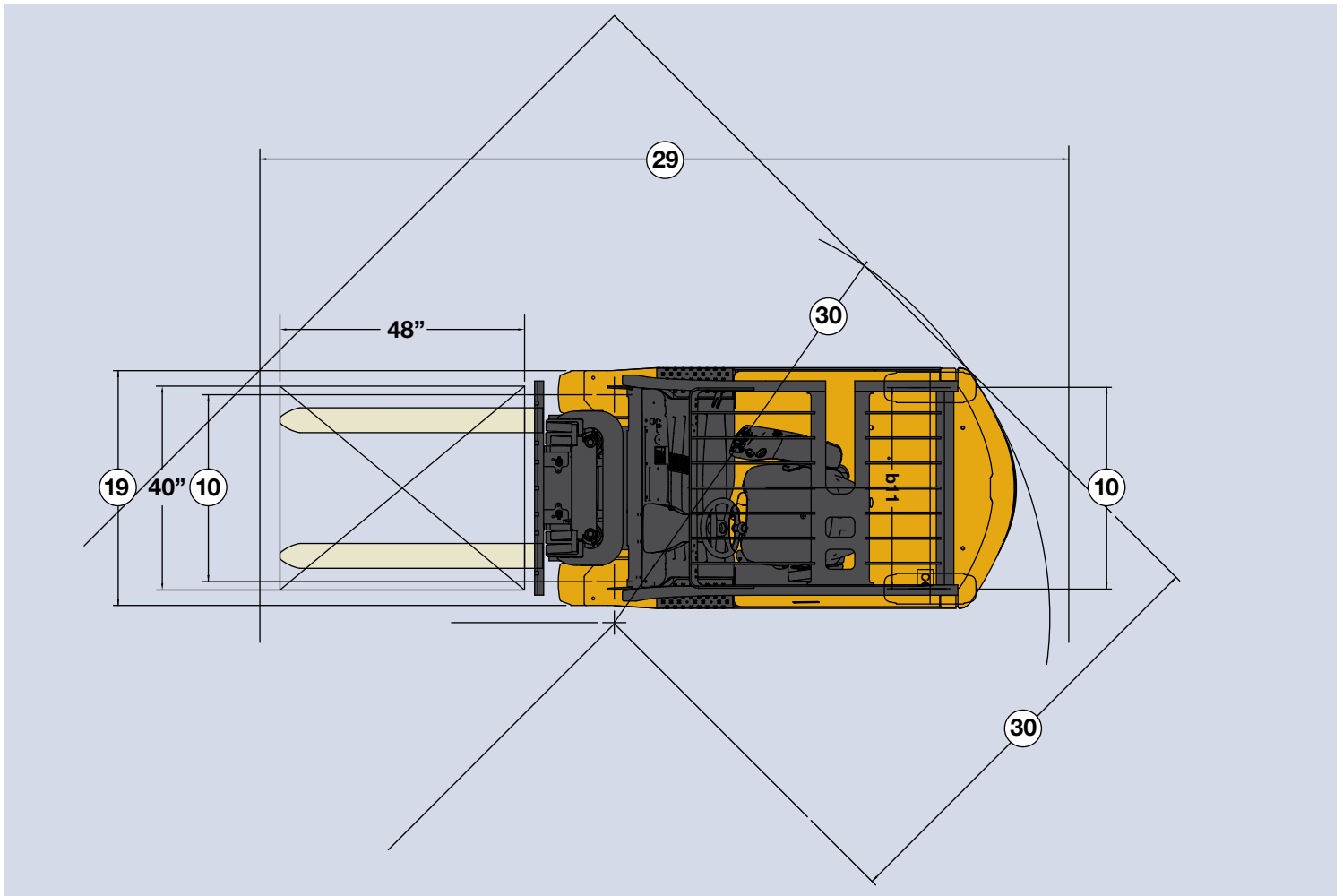

GENERAL	1	Manufacturer			Yale			
	2	Model Designation			ERC080VH			
	3	Power			Electric			
	4	Operation			Sit			
	5	Rated Capacity		lb. (kg)	8000 (3629)			
	6	Load Center		in. (mm)	24 (610)			
TIRES/WHEELS	7	Tire Type - Cushion, Solid, Pneumatic, etc.		Drive / Steer	Cushion / Cushion			
	8	Tire Size		Drive / Steer	22 x 9 x 16 / 18 x 6 x 12.1			
	9	Wheels - Number	X=Driven	Drive / Steer	2X / 2			
	10	Tread	Center of Tires	Narr Dr / Wide Dr / Steer	in. (mm)	37 / 41 / 39.5 (941 / 1041 / 1003)		
DIMENSIONS	11	Mast Tilt		Std Opt	degrees	5F / 5B 8F / 5B		
	12	Mast - Lowered Height		Std Mast	in. (mm)	84.1 (2134)		
	13	Free Lift - Top of Fork	Std 2 Stg Limited Free Lift Mast		in. (mm)	5 (150)		
			Opt 2 Stg Full Free Lift Mast with / without LBR		in. (mm)	35 / 53 (900 / 1352)		
	14	Lift Height - Top of Fork		Std 2 Stg Limited Free Lift Mast	in. (mm)	120 (3050)		
	15	Mast - Extended Height		Std Mast with / without LBR	in. (mm)	169 / 149 (4284 / 3783)		
	16	Overhead Guard Height		Std / Opt / Opt Flat Plate	in. (mm)	94 / 91 / 87.1 (2388 / 2311 / 2212)		
	17	SIP to Bottom Std OHG	Seat Depressed	Std / Susp / Swivel	in. (mm)	38.7 / 38.9 / 38.9 (984 / 989 / 989)		
	18	Tow Pin Height		Vertical Center of Pin	in. (mm)	12.7 (324)		
	19	Overall Width		Standard Tread / Wide Tread	in. (mm)	47.2 / 50 (1200 / 1270)		
	20	Forks		Thickness x Width x Length	in. (mm)	2 x 4.9 x 42 (50 x 125 x 1067)		
	21	Standard Carriage Width		Class III	in. (mm)	42 (1067)		
	22	Floor to Top of Battery Rollers			in. (mm)	20 (509)		
	23	Ground Clearance	Lowest Point	NL / RL	in. (mm)	3.8 / 3.5 (96 / 90)		
	24	Ground Clearance	Center of Truck	NL / RL	in. (mm)	5.3 / 5.1 (134 / 130)		
	25	Load Distance		Center of Wheel to Face of Forks	in. (mm)	17.6 (447)		
	26	Battery Compartment	Height	Without / With Battery Rollers	in. (mm)	24.4 / 24 (620 / 609)		
			Width		in. (mm)	45.4 (1152)		
				Nominal	SIZE	39		
				Length	Actual	in. (mm)	39.2 (996)	
	27	Length to Face of Forks		Chassis Length	in. (mm)	96.5 (2451)		
	28	Wheelbase			in. (mm)	62 (1574)		
	29	Right Angle Stack			in. (mm)	150.8 (3831)		
	30	Equal Aisle	90° Intersecting Aisle		in. (mm)	79.4 (2017)		
	31	Outside Turning Radius			in. (mm)	85.2 (2165)		
	WEIGHT	32	Truck Weight	Without Battery	NL	lb. (kg)	11070 (5021)	
		33	Axle Loading - Drive	Static with Max. Wt. Battery	NL / RL	lb. (kg)	6728 / 20098 (3052 / 9116)	
		34	Axle Loading - Steer	Static with Max. Wt. Battery	NL / RL	lb. (kg)	9141 / 3771 (4146 / 1710)	
	PERFORMANCE					Standard Performance		
					VOLTS	36	48	80
		36	Travel Speed	Extended Shift OFF	NL / RL	mph (km/h)	11.4 / 9.7 (18.3 / 15.6)	12.7 / 12.2 (20.4 / 19.6)
		Extended Shift ON		NL / RL	mph (km/h)	9.8 / 8.4 (15.8 / 13.5)	12.5 / 10.8 (20.1 / 17.4)	12.5/10.8 (20.1/17.4)
37		Lift Speed	Std 2 Stg LFL Mast	NL / RL	ft/min (m/sec)	94 / 58 (0.48 / 0.296)	118 / 73 (0.6 / 0.37)	118/73 (0.6/0.37)
			Opt 2 Stg FFL Mast	NL / RL	ft/min (m/sec)	85 / 53 (0.4336 / 0.267)	107 / 66 (0.542 / 0.334)	107/66 (0.542/0.334)
			Opt 3 Stg FFL Mast	NL / RL	ft/min (m/sec)	88 / 54 (0.448 / 0.276)	110 / 68 (0.56 / 0.345)	110/68 (0.56/0.345)
38		Lower Speed	Std 2 Stg LFL Mast	NL / RL	ft/min (m/sec)	94 / 104 (0.48 / 0.53)		
			Opt 2 Stg FFL Mast	NL / RL	ft/min (m/sec)	75 / 91 (0.38 / 0.46)		
			Opt 3 Stg FFL Mast	NL / RL	ft/min (m/sec)	77 / 98 (0.39 / 0.5)		
39		Gradability	5 Minute Rating	NL / RL	%	23 / 14.1	29.3 / 17.8	30.1 / 18.3
			60 Minute Rating	NL / RL	%	8.4 / 5.4	10.6 / 6.8	10.9 / 7
40		Drawbar Pull	5 Minute Rating	NL / RL	lbf	3327 / 3193	4023 / 3864	4104 / 3941
			60 Minute Rating	NL / RL	lbf	1246 / 1232	1511 / 1497	1541 / 1526
41		Brake	Method of Control	Service / Parking		Hydraulic / Spring Applied		
	Method of Operation		Service / Parking		Foot / Automatic			
ELECTRIC	42	Battery		Type	Lead Acid			
					Standard Performance			
					VOLTS	36	48	80
	43	Traction Motor		60 Minute Rating	hp (kW)	28.8 (21.5)	28.8 (21.5)	28.2 (21)
	44	Pump Motor		15 % Rating	hp (kW)	35.5 (26.5)	48.3 (36)	48.3 (36)
	45	Traction Motor		Type / Control Method	AC / Transistor			
46	Pump Motor		Type / Control Method	AC / Transistor				
47	Number of Speeds		Traction / Pump	Infinitely Variable / Infinitely Variable				
OTHER	48	Step Height		in. (mm)	21.1 (536)			
	49	Floor Height		Lowest Point	in. (mm)	33.7 (855)		
	50	Attachment Relief Pressure		psi (bar)	2248 (155)			
	51	Auxiliary Oil Flow	3rd and 4th Function		gal/min (l/min)	16 (60)		
	52	Sound Level		Measured per ANSI B56.11.5	dB (A)	69/66		

Above specifications, unless otherwise listed, are for a standard truck without optional equipment.

Right Angle Stack and Equal Intersecting Aisle dimensions provided with a 48" long and 40" wide pallet load, allowing zero clearance.

GENERAL	1	Manufacturer			Yale			
	2	Model Designation			ERC100VHS			
	3	Power			Electric			
	4	Operation			Sit			
	5	Rated Capacity		lb. (kg)	10000 (4536)			
	6	Load Center		in. (mm)	24 (610)			
TIRES/WHEELS	7	Tire Type - Cushion, Solid, Pneumatic, etc.		Drive / Steer	Cushion / Cushion			
	8	Tire Size		Drive / Steer	in. 22 x 12 x 16 / 18 x 7 x 12.1			
	9	Wheels - Number	X=Driven	Drive / Steer	2X / 2			
DIMENSIONS	10	Tread	Center of Tires	Narr Dr / Wide Dr / Steer	in. (mm)	40 / 43.9 / 38.3 (1015 / 1115 / 972)		
	11	Mast Tilt		Std Opt	degrees	5F / 5B 8F / 5B		
	12	Mast - Lowered Height		Std Mast	in. (mm)	84.2 (2138)		
	13	Free Lift - Top of Fork	Std 2 Stg Limited Free Lift Mast		in. (mm)	5 (150)		
			Opt 2 Stg Full Free Lift Mast with / without LBR		in. (mm)	35 / 48 (897 / 1222)		
	14	Lift Height - Top of Fork		Std 2 Stg Limited Free Lift Mast	in. (mm)	109 (2790)		
	15	Mast - Extended Height		Std Mast with / without LBR	in. (mm)	159 / 144 (4031 / 3657)		
	16	Overhead Guard Height		Std / Opt / Opt Flat Plate	in. (mm)	94 / 91 / 87.1 (2388 / 2311 / 2212)		
	17	SIP to Bottom Std OHG	Seat Depressed	Std / Susp / Swivel	in. (mm)	38.7 / 38.9 / 38.9 (984 / 989 / 989)		
	18	Tow Pin Height		Vertical Center of Pin	in. (mm)	12.7 (324)		
	19	Overall Width		Standard Tread / Wide Tread	in. (mm)	52 / 55.9 (1320 / 1420)		
	20	Forks		Thickness x Width x Length	in. (mm)	2 x 5.9 x 42 (50 x 150 x 1067)		
	21	Standard Carriage Width		Class III	in. (mm)	42 (1067)		
	22	Floor to Top of Battery Rollers			in. (mm)	20 (509)		
	23	Ground Clearance	Lowest Point	NL / RL	in. (mm)	3.6 / 3.4 (92 / 87)		
	24	Ground Clearance	Center of Truck	NL / RL	in. (mm)	5.3 / 5.1 (134 / 130)		
	25	Load Distance		Center of Wheel to Face of Forks	in. (mm)	17.8 (452)		
	26	Battery Compartment	Height	Without / With Battery Rollers	in. (mm)	24.4 / 24 (620 / 609)		
			Width		in. (mm)	45.4 (1152)		
				Nominal	SIZE	39"		
				Actual	in. (mm)	39.2 (996)		
	27	Length to Face of Forks		Chassis Length	in. (mm)	100.3 (2548)		
	28	Wheelbase			in. (mm)	62 (1574)		
	29	Right Angle Stack			in. (mm)	154 (3911)		
30	Equal Aisle	90° Intersecting Aisle		in. (mm)	83 (2107)			
31	Outside Turning Radius			in. (mm)	88.2 (2240)			
WEIGHT	32	Truck Weight	Without Battery	NL	lb. (kg)	13070 (5928)		
	33	Axle Loading - Drive	Static with Max. Wt. Battery	NL / RL	lb. (kg)	6798 / 23542 (3084 / 10678)		
	34	Axle Loading - Steer	Static with Max. Wt. Battery	NL / RL	lb. (kg)	11069 / 4325 (5021 / 1962)		
PERFORMANCE					Standard Performance			
					VOLTS	36	48	80
	36	Travel Speed	Extended Shift OFF	NL / RL	mph (km/h)	10.3 / 8.8 (16.6 / 14.2)	11.4 / 11 (18.3 / 17.7)	11.4 / 11 (18.3 / 17.7)
			Extended Shift ON	NL / RL	mph (km/h)	9.1 / 7.7 (14.6 / 12.4)	11.4 / 9.9 (18.3 / 15.9)	11.4 / 9.9 (18.3 / 15.9)
	37	Lift Speed	Std 2 Stg LFL Mast	NL / RL	ft/min (m/sec)	71 / 46 (0.36 / 0.232)	89 / 57 (0.45 / 0.29)	89 / 57 (0.45 / 0.29)
			Opt 2 Stg FFL Mast	NL / RL	ft/min (m/sec)	67 / 43 (0.34 / 0.219)	84 / 54 (0.425 / 0.274)	84 / 54 (0.425 / 0.274)
			Opt 3 Stg FFL Mast	NL / RL	ft/min (m/sec)	68 / 44 (0.346 / 0.223)	85 / 55 (0.433 / 0.279)	85 / 55 (0.433 / 0.279)
	38	Lower Speed	Std 2 Stg LFL Mast	NL / RL	ft/min (m/sec)	73 / 89 (0.37 / 0.45)		
			Opt 2 Stg FFL Mast	NL / RL	ft/min (m/sec)	57 / 81 (0.29 / 0.41)		
			Opt 3 Stg FFL Mast	NL / RL	ft/min (m/sec)	63 / 87 (0.32 / 0.44)		
	39	Gradability	5 Minute Rating	NL / RL	%	19.4 / 11.8	24.6 / 14.7	25.2 / 15.1
			60 Minute Rating	NL / RL	%	7.1 / 4.5	9.1 / 5.6	9.2 / 5.8
	40	Drawbar Pull	5 Minute Rating	NL / RL	lbf	3323 / 3185	3994 / 3832	4074 / 3909
			60 Minute Rating	NL / RL	lbf	1242 / 1224	1497 / 1479	1527 / 1509
41	Brake	Method of Control	Service / Parking		Hydraulic / Spring Applied			
		Method of Operation	Service / Parking		Foot / Automatic			
ELECTRIC	42	Battery		Type	Lead Acid			
					Standard Performance			
					VOLTS	36	48	80
	43	Traction Motor	60 Minute Rating		hp (kW)	28.8 (21.5)	28.8 (21.5)	28.2 (21)
			15 % Rating		hp (kW)	35.5 (26.5)	48.3 (36)	48.3 (36)
45	Traction Motor		Type / Control Method		AC / Transistor			
46	Pump Motor		Type / Control Method		AC / Transistor			
47	Number of Speeds		Traction / Pump		Infinitely Variable / Infinitely Variable			
OTHER	48	Step Height		in. (mm)	21.1 (536)			
	49	Floor Height		Lowest Point	in. (mm)	33.7 (855)		
	50	Attachment Relief Pressure			psi (bar)	2248 (155)		
	51	Auxiliary Oil Flow	3rd and 4th Function		gal/min (l/min)	16 (60)		
	52	Sound Level		Measured per ANSI B56.11.5		dB (A)	69/66	

Above specifications, unless otherwise listed, are for a standard truck without optional equipment.

Right Angle Stack and Equal Intersecting Aisle dimensions provided with a 48" long and 40" wide pallet load, allowing zero clearance.

GENERAL	1	Manufacturer			Yale			
	2	Model Designation			ERC100VH			
	3	Power			Electric			
	4	Operation			Sit			
	5	Rated Capacity		lb. (kg)	10000 (4536)			
TIRES/WHEELS	6	Load Center		in. (mm)	24 (610)			
	7	Tire Type - Cushion, Solid, Pneumatic, etc.		Drive / Steer	Cushion / Cushion			
	8	Tire Size		in.	22 x 12 x 16 / 18 x 7 x 12.1			
	9	Wheels - Number	X=Driven	Drive / Steer	2X / 2			
	10	Tread	Center of Tires	Narr Dr / Wide Dr / Steer	in. (mm)	40 / 43.9 / 38.3 (1015 / 1115 / 972)		
DIMENSIONS	11	Mast Tilt		Std Opt	degrees	5F / 5B 8F / 5B		
	12	Mast - Lowered Height		Std Mast	in. (mm)	84.2 (2138)		
	13	Free Lift - Top of Fork	Std 2 Stg Limited Free Lift Mast		in. (mm)	5 (150)		
			Opt 2 Stg Full Free Lift Mast with / without LBR		in. (mm)	35 / 48 (897 / 1222)		
	14	Lift Height - Top of Fork	Std 2 Stg Limited Free Lift Mast		in. (mm)	109 (2790)		
	15	Mast - Extended Height	Std Mast with / without LBR		in. (mm)	159 / 144 (4031 / 3657)		
	16	Overhead Guard Height	Std / Opt / Opt Flat Plate		in. (mm)	94 / 91 / 87.1 (2388 / 2311 / 2212)		
	17	SIP to Bottom Std OHG	Seat Depressed	Std / Susp / Swivel	in. (mm)	38.7 / 38.9 / 38.9 (984 / 989 / 989)		
	18	Tow Pin Height	Vertical Center of Pin		in. (mm)	12.7 (324)		
	19	Overall Width	Standard Tread / Wide Tread		in. (mm)	52 / 55.9 (1320 / 1420)		
	20	Forks	Thickness x Width x Length		in. (mm)	2 x 5.9 x 42 (50 x 150 x 1067)		
	21	Standard Carriage Width	Class III		in. (mm)	42 (1067)		
	22	Floor to Top of Battery Rollers			in. (mm)	20 (509)		
	23	Ground Clearance	Lowest Point	NL / RL	in. (mm)	3.6 / 3.4 (92 / 87)		
	24	Ground Clearance	Center of Truck	NL / RL	in. (mm)	5.3 / 5.1 (134 / 130)		
	25	Load Distance	Center of Wheel to Face of Forks		in. (mm)	17.8 (452)		
	26	Battery Compartment	Height	Without / With Battery Rollers	in. (mm)	24.4 / 24 (620 / 609)		
			Width		in. (mm)	45.4 (1152)		
				Nominal	SIZE	45"		
			Length	Actual	in. (mm)	45.7 (1161)		
	27	Length to Face of Forks	Chassis Length		in. (mm)	103.1 (2621)		
	28	Wheelbase			in. (mm)	68.5 (1739)		
	29	Right Angle Stack			in. (mm)	158 (4012)		
	30	Equal Aisle	90° Intersecting Aisle		in. (mm)	84.3 (2141)		
	31	Outside Turning Radius			in. (mm)	92.2 (2341)		
	WEIGHT	32	Truck Weight	Without Battery	NL	lb. (kg)	12300 (5579)	
		33	Axle Loading - Drive	Static with Max. Wt. Battery	NL / RL	lb. (kg)	7708 / 23813 (3496 / 10801)	
		34	Axle Loading - Steer	Static with Max. Wt. Battery	NL / RL	lb. (kg)	10139 / 4035 (4599 / 1830)	
	PERFORMANCE					Standard Performance		
					VOLTS	36	48	80
		36	Travel Speed	Extended Shift OFF	NL / RL	mph (km/h)	10.3 / 8.8 (16.6 / 14.2)	11.4 / 11 (18.3 / 17.7)
			Extended Shift ON	NL / RL	mph (km/h)	9.1 / 7.7 (14.6 / 12.4)	11.4 / 9.9 (18.3 / 15.9)	11.4 / 9.9 (18.3 / 15.9)
37		Lift Speed	Std 2 Stg LFL Mast	NL / RL	ft/min (m/sec)	71 / 46 (0.36 / 0.232)	89 / 57 (0.45 / 0.29)	89 / 57 (0.45 / 0.29)
			Opt 2 Stg FFL Mast	NL / RL	ft/min (m/sec)	67 / 43 (0.34 / 0.219)	84 / 54 (0.425 / 0.274)	84 / 54 (0.425 / 0.274)
			Opt 3 Stg FFL Mast	NL / RL	ft/min (m/sec)	68 / 44 (0.346 / 0.223)	85 / 55 (0.433 / 0.279)	85 / 55 (0.433 / 0.279)
38		Lower Speed	Std 2 Stg LFL Mast	NL / RL	ft/min (m/sec)	73 / 89 (0.37 / 0.45)		
			Opt 2 Stg FFL Mast	NL / RL	ft/min (m/sec)	57 / 81 (0.29 / 0.41)		
			Opt 3 Stg FFL Mast	NL / RL	ft/min (m/sec)	63 / 87 (0.32 / 0.44)		
39		Gradability	5 Minute Rating	NL / RL	%	19.9 / 11.9	25.2 / 15	25.8 / 15.3
			60 Minute Rating	NL / RL	%	7.3 / 4.5	9.2 / 5.7	9.4 / 5.9
40		Drawbar Pull	5 Minute Rating	NL / RL	lbf	3322 / 3185	3970 / 3809	4049 / 3885
	60 Minute Rating		NL / RL	lbf	1241 / 1224	1488 / 1470	1518 / 1500	
41	Brake	Method of Control	Service / Parking	Hydraulic / Spring Applied				
		Method of Operation	Service / Parking	Foot / Automatic				
ELECTRIC	42	Battery		Type	Lead Acid			
					Standard Performance			
				VOLTS	36	48	80	
	43	Traction Motor	60 Minute Rating	hp (kW)	28.8 (21.5)	28.8 (21.5)	28.2 (21)	
	44	Pump Motor	15 % Rating	hp (kW)	35.5 (26.5)	48.3 (36)	48.3 (36)	
45	Traction Motor	Type / Control Method		AC / Transistor				
46	Pump Motor	Type / Control Method		AC / Transistor				
47	Number of Speeds		Traction / Pump	Infinitely Variable / Infinitely Variable				
OTHER	48	Step Height		in. (mm)	21.1 (536)			
	49	Floor Height		Lowest Point	in. (mm)	33.7 (855)		
	50	Attachment Relief Pressure			psi (bar)	2248 (155)		
	51	Auxiliary Oil Flow	3rd and 4th Function		gal/min (l/min)	16 (60)		
	52	Sound Level		Measured per ANSI B56.11.5		dB (A)		69/66

Above specifications, unless otherwise listed, are for a standard truck without optional equipment.

Right Angle Stack and Equal Intersecting Aisle dimensions provided with a 48" long and 40" wide pallet load, allowing zero clearance.

GENERAL	1	Manufacturer			Yale			
	2	Model Designation			ERC120VH			
	3	Power			Electric			
	4	Operation			Sit			
	5	Rated Capacity		lb. (kg)	12000 (5443)			
	6	Load Center		in. (mm)	24 (610)			
TIRES/WHEELS	7	Tire Type - Cushion, Solid, Pneumatic, etc.		Drive / Steer	Cushion / Cushion			
	8	Tire Size		Drive / Steer	in. 22 x 12 x 16 / 18 x 7 x 12.1			
	9	Wheels - Number	X=Driven	Drive / Steer	2X / 2			
DIMENSIONS	10	Tread	Center of Tires	Narr Dr / Wide Dr / Steer	in. (mm)	40 / 43.9 / 38.3 (1015 / 1115 / 972)		
	11	Mast Tilt		Std Opt	degrees	5F / 5B 8F / 5B		
	12	Mast - Lowered Height		Std Mast	in. (mm)	84.2 (2138)		
	13	Free Lift - Top of Fork	Std 2 Stg Limited Free Lift Mast		in. (mm)	5 (150)		
			Opt 2 Stg Full Free Lift Mast with / without LBR		in. (mm)	35 / 48 (897 / 1222)		
	14	Lift Height - Top of Fork		Std 2 Stg Limited Free Lift Mast	in. (mm)	109 (2790)		
	15	Mast - Extended Height		Std Mast with / without LBR	in. (mm)	159 / 144 (4031 / 3657)		
	16	Overhead Guard Height		Std / Opt / Opt Flat Plate	in. (mm)	94 / 91 / 87.1 (2388 / 2311 / 2212)		
	17	SIP to Bottom Std OHG	Seat Depressed	Std / Susp / Swivel	in. (mm)	38.7 / 38.9 / 38.9 (984 / 989 / 989)		
	18	Tow Pin Height		Vertical Center of Pin	in. (mm)	12.7 (324)		
	19	Overall Width		Standard Tread / Wide Tread	in. (mm)	52 / 55.9 (1320 / 1420)		
	20	Forks		Thickness x Width x Length	in. (mm)	2.4 x 5.9 x 42 (60 x 150 x 1067)		
	21	Standard Carriage Width		Class III	in. (mm)	42 (1067)		
	22	Floor to Top of Battery Rollers			in. (mm)	20 (509)		
	23	Ground Clearance	Lowest Point	NL / RL	in. (mm)	3.6 / 3.4 (92 / 87)		
	24	Ground Clearance	Center of Truck	NL / RL	in. (mm)	5.3 / 5.1 (134 / 130)		
	25	Load Distance		Center of Wheel to Face of Forks	in. (mm)	18.2 (462)		
	26	Battery Compartment	Height		Without / With Battery Rollers	in. (mm)	24.4 / 24 (620 / 609)	
			Width			in. (mm)	45.4 (1152)	
					Nominal	SIZE	45"	
			Length		Actual	in. (mm)	45.7 (1161)	
	27	Length to Face of Forks		Chassis Length	in. (mm)	107.2 (2724)		
	28	Wheelbase			in. (mm)	68.5 (1739)		
	29	Right Angle Stack			in. (mm)	161.5 (4101)		
30	Equal Aisle	90° Intersecting Aisle		in. (mm)	85.7 (2178)			
31	Outside Turning Radius			in. (mm)	95.3 (2420)			
WEIGHT	32	Truck Weight	Without Battery	NL	lb. (kg)	13860 (6287)		
	33	Axle Loading - Drive	Static with Max. Wt. Battery	NL / RL	lb. (kg)	7556 / 26951 (3427 / 12225)		
	34	Axle Loading - Steer	Static with Max. Wt. Battery	NL / RL	lb. (kg)	11848 / 4453 (5374 / 2020)		
PERFORMANCE					Standard Performance			
					VOLTS	36	48	80
	36	Travel Speed	Extended Shift OFF	NL / RL	mph (km/h)	9.4 / 8 (15.1 / 12.9)	10.4 / 10 (16.7 / 16.1)	10.4 / 10 (16.7 / 16.1)
			Extended Shift ON	NL / RL	mph (km/h)	8.2 / 7 (13.2 / 11.3)	10.4 / 9 (16.7 / 14.5)	10.4 / 9 (16.7 / 14.5)
	37	Lift Speed	Std 2 Stg LFL Mast	NL / RL	ft/min (m/sec)	71 / 43 (0.36 / 0.216)	89 / 53 (0.45 / 0.27)	89 / 53 (0.45 / 0.27)
			Opt 2 Stg FFL Mast	NL / RL	ft/min (m/sec)	67 / 40 (0.34 / 0.204)	84 / 50 (0.425 / 0.255)	84 / 50 (0.425 / 0.255)
			Opt 3 Stg FFL Mast	NL / RL	ft/min (m/sec)	68 / 41 (0.346 / 0.208)	85 / 51 (0.433 / 0.26)	85 / 51 (0.433 / 0.26)
	38	Lower Speed	Std 2 Stg LFL Mast	NL / RL	ft/min (m/sec)	73 / 89 (0.37 / 0.45)		
			Opt 2 Stg FFL Mast	NL / RL	ft/min (m/sec)	57 / 81 (0.29 / 0.41)		
			Opt 3 Stg FFL Mast	NL / RL	ft/min (m/sec)	63 / 87 (0.32 / 0.44)		
	39	Gradability	5 Minute Rating	NL / RL	%	18.5 / 10.4	22.8 / 13.1	23.3 / 13.4
			60 Minute Rating	NL / RL	%	6.6 / 4	8.3 / 5.1	8.5 / 5.1
	40	Drawbar Pull	5 Minute Rating	NL / RL	lbf	3320 / 3179	3918 / 3755	3996 / 3830
			60 Minute Rating	NL / RL	lbf	1239 / 1218	1466 / 1445	1495 / 1474
	41	Brake	Method of Control		Service / Parking	Hydraulic / Spring Applied		
Method of Operation			Service / Parking	Foot / Automatic				
ELECTRIC	42	Battery		Type	Lead Acid			
					Standard Performance			
					VOLTS	36	48	80
	43	Traction Motor		60 Minute Rating	hp (kW)	28.8 (21.5)	28.8 (21.5)	28.2 (21)
	44	Pump Motor		15 % Rating	hp (kW)	35.5 (26.5)	48.3 (36)	48.3 (36)
45	Traction Motor		Type / Control Method	AC / Transistor				
46	Pump Motor		Type / Control Method	AC / Transistor				
47	Number of Speeds		Traction / Pump	Infinitely Variable / Infinitely Variable				
OTHER	48	Step Height		in. (mm)	21.1 (536)			
	49	Floor Height		Lowest Point	in. (mm)	33.7 (855)		
	50	Attachment Relief Pressure			psi (bar)	2248 (155)		
	51	Auxiliary Oil Flow	3rd and 4th Function		gal/min (l/min)	16 (60)		
	52	Sound Level		Measured per ANSI B56.11.5	dB (A)	69/66		

Above specifications, unless otherwise listed, are for a standard truck without optional equipment.

Right Angle Stack and Equal Intersecting Aisle dimensions provided with a 48" long and 40" wide pallet load, allowing zero clearance.

ERC80VH MAST DIMENSIONS

Maximum Fork Height (TOF) +	Overall Lowered Ht.	Overall Extended Height w/Load Backrest	Overall Extended Height w/o Load Backrest	Free-Lift (TOF) w/ Load Backrest	Free-Lift (TOF) w/o Load Backrest
in. (mm)	in. (mm)	in. (mm)	in. (mm)	in. (mm)	in. (mm)
2-STAGE LIMITED FREE-LIFT (LFL) MAST					
120 (3050)	84 (2134)	176 (4455)	149 (3783)	5 (150)	5 (150)
143 (3650)	96 (2434)	193 (4884)	173 (4383)	5 (150)	5 (150)
2-STAGE FULL FREE-LIFT (FFL) MAST					
121 (3075)	84 (2134)	170 (4309)	152 (3857)	35 (900)	53 (1352)
144 (3675)	96 (2434)	194 (4909)	176 (4457)	47 (1200)	65 (1652)
3-STAGE FULL FREE-LIFT (FFL) MAST					
173 (4415)	84 (2134)	223 (5649)	205 (5197)	35 (900)	53 (1352)
185 (4715)	88 (2234)	235 (5949)	217 (5497)	39 (1000)	57 (1452)
194 (4950)	92 (2334)	244 (6184)	226 (5732)	43 (1100)	61 (1552)
218 (5550)	100 (2534)	268 (6784)	250 (6332)	51 (1300)	69 (1752)

ERC100-120VH MAST DIMENSIONS

Maximum Fork Height (TOF) +	Overall Lowered Ht.	Overall Extended Height w/Load Backrest	Overall Extended Height w/o Load Backrest	Free-Lift (TOF) w/ Load Backrest	Free-Lift (TOF) w/o Load Backrest
in. (mm)	in. (mm)	in. (mm)	in. (mm)	in. (mm)	in. (mm)
2-STAGE LIMITED FREE-LIFT (LFL) MAST					
109 (2790)	85 (2138)	159 (4031)	144 (3657)	5 (150)	5 (150)
133 (3390)	96 (2438)	183 (4631)	168 (4257)	5 (150)	5 (150)
157 (3990)	108 (2738)	206 (5231)	192 (4857)	5 (150)	5 (150)
2-STAGE FULL FREE-LIFT (FFL) MAST					
110 (2815)	85 (2138)	160 (4056)	147 (3731)	35 (897)	48 (1222)
134 (3415)	96 (2438)	184 (4656)	171 (4331)	47 (1197)	59 (1522)
3-STAGE FULL FREE-LIFT (FFL) MAST					
162 (4137)	85 (2138)	212 (5378)	200 (5058)	35 (897)	47 (1217)
184 (4690)	92 (2338)	234 (5931)	221 (5611)	43 (1097)	55 (1417)
208 (5290)	100 (2538)	258 (6531)	245 (6211)	51 (1297)	63 (1617)

BATTERY AND COMPARTMENT SPECIFICATIONS

Truck Model	Compartment Dim			Battery Dim - Max			Volts	No. of Cells	Plates per Cell	Max Capacity 6 Hour Rate	Weight	
	Width	Length	Height	"X"	"Y"	"Z"					Min	Max
	in (mm)			in (mm)							amp hr (kwh)	
ERC080VH ERC100VHS 39" Compartment	45.4 (1152)	39.2 (996)	24.5 (622)	45 (1143)	39 (990)	23.9 (608)	36	18	33	2300 (80.3)	3400 (1542)	4800 (2177)
							48	24	29	1800 (83.8)		
							80	40	15	1000 (77.6)		
ERC100VH ERC120VH 45" Compartment	45.4 (1152)	45.7 (1161)	24.5 (622)	45 (1143)	45.3 (1150)	23.9 (608)	36	36	19	2300 (160.6)	4000 (1814)	5500 (2517)
							48	24	33	1800 (83.8)		
							80	40	17	1000 (77.6)		

Battery Type: "EO" (Without Cover)

Battery amp hr (kwh) capacity is max allowable per UL

Commercially available lead acid batteries may not necessarily reach these max limits

Battery Roller option reduces battery compartment height to 24.0" (609mm) & max battery height to 23.4" (595mm)

Battery Compartment Length is measured front to rear. Battery Compartment Width is measured across the truck

Battery Notes - Conventional Charging (Opt G26201)

Battery Connector: 36 volt - Grey SB®350 (Anderson Power Products® P/N 6320G2 or equivalent)

48 volt - Blue SB®350 (Anderson Power Products® P/N 6321G2 or equivalent)

80 volt - Black SBE®320 (Anderson Power Products® P/N E6359G3 or equivalent)

Handle (not required): SB®350 and SBE®320 (Anderson Power Products®: "A" TYPE (Grey) P/N 995G2 or equivalent)

Battery Lead: Length 20" (508 mm), Position "B", 4/0 AWG

Battery Notes - Rapid / Fast Charging (Opt G26202)

Battery Connector: Requires Dual Positive / Negative Cabling terminating in (2) Female EBC-320 DIN Connectors (Anderson Power Products® P/N E32504-00X9 or equivalent)

Each individual DIN connector to include 1 Red Conductor to (+) and 1 black conductor to (-)

Battery Lead: Length 25" (635 mm), Position "B", Minimum Cable Size 4/0 AWG

(continued from cover)

FOOT DIRECTIONAL CONTROL PEDAL (FDC) (OPTIONAL)

The foot directional control pedal is a highly productive directional/accelerator pedal. One pedal allows the operator to change direction and acceleration reducing operator movement resulting in increased productivity.

HYDRAULIC COMPONENTS

A transistor control hydraulic system is powered by a brushless, AC induction motor with maintenance free wet spline coupling that joins the motor to the pump for long drive life and low noise. The motor and pump are mounted on rubber isolators for reduced noise and vibration. A combination of flexible wire-braid hoses and steel tubing is used to simplify the hydraulic plumbing. These hydraulic lines are carefully routed and held in place to reduce possible damage. A 10-Micron full flow hydraulic filter located in the return line protects the hydraulic system from contaminants and helps provide long life. A by-pass relief valve permits oil flow in the event of the filter clogging.

HYDROSTATIC POWER STEERING

Hydrostatic power steering is standard and the all-hydraulic design gives precise, reliable control while eliminating mechanical linkages and road shocks at the steering wheel. An infinitely adjustable tilt steering column provides excellent operator comfort and visibility.

DRIVE/STEERING AXLE

The drive axle consists of a three-piece cast ductile iron housing and is a full floating axle. The steering axle is a one-piece ductile iron casting mounted on

elastic cushions that reduce shock and provide a softer ride. The Continuous Stability System (CSS™) enhances truck stability in a simple, maintenance free design, without compromising uneven surface travel.

MASTS\CARRIAGE\FORKS\LOAD BACKREST EXTENSION

Yale® Global Hi-Vis™ simplex, duplex and triplex masts provide excellent visibility. The mast features flush face design with geometrically matched, angled load rollers, which are canted, yet provide full-face roller contact. The mast front rail flange angle coupled with the inverted “J” inner channel and three degree mast rollers significantly reduces channel web milling and roller wear. Trunnion mast mounting allows masts to be mounted with the shortest possible load distance (center of front wheel to face of forks) to maximize truck maneuverability. The mounting is standardized for direct mast interchangeability on a variety of Yale truck models without modification. Class III six-roller carriages are standard on the ERC080VH and Class IV six-roller carriages are standard on the ERC100-120VH. Forks are “upset forged” from a single piece of high-strength steel giving added strength and thickness for wear. A 48” load backrest extension is standard.

FRAME

The frame is a unitized construction, stress tested for durability. An integral step on both sides of the truck is provided for easy entry and exit. The truck has a two-piece floor plate that can be easily lifted out for service access. An easily removable counterweight top cover gives easy access

to components. A stamped steel spring-assisted hood allows easy changing of the battery. The battery compartment can be fitted with rollers.

ADDITIONAL FEATURES

Additional features on the ERC-VH include an overhead guard, 42” forks, non-suspension seat, seat belt and an operator sensing system. An infinitely adjustable tilt steering column, rubber floor mat, and electronic horn are also standard.

OPTIONS

Accutouch e-hydraulics Mini-levers
Foot Directional Control Pedal
Return to set tilt
Telescoping Steering Column with Tilt Memory
Rapid charge
Cooler/freezer package
Wide tread
Full suspension seats (with and without swivel)
Red (Hi-Vis) ELR non-cinch seat belt
Battery rollers
Overhead guard mounted headlights
Lowered overhead guard
LED and Halogen work light/tail light packages
LED Dome/reading light
8° forward tilt
Integral sidershifter
48, 80 volt
Audible Alarm – Reverse Operation
Light - Amber strobe
Various type drive tires
Type “EE” UL construction
Dual Rear View Mirrors
Panoramic Rear View Mirrors
Fire Extinguisher
Accumulator

Truck performance may be affected by the condition of the vehicle, how it is equipped and the application. Consult your Yale® Industrial Truck Dealer if any of the information shown is critical to your application. Specifications are subject to change without notice.

This truck meets all design specifications of ANSI B56.1 Safety Standard for Powered Industrial Trucks at the time of manufacture.

Classified by Underwriters' Laboratories, Inc. as fire hazard only. The Yale products included in this document may be covered by US patent 6,684,148 and other patents pending.



Yale Materials Handling Corporation
P.O. Box 7367, Greenville, North Carolina 27835-7367

© 2012 Yale Materials Handling Corporation.  is a registered copyright of Yale Materials Handling Corporation. YALE and VERACITOR are registered trademarks of Yale Materials Handling Corporation. PREMIER is a trademark of Yale Materials Handling Corporation.

2362-1A 11/12

Manufactured in our own ISO 9001 and 14001 Registered Facilities